



RULLO



INTERNI



CASSONETTO



GUIDE



OSCURANTE



MOTORE





Mod. MBECGA - Fissaggio autoportante - dimensioni e ingombri

Tenda sostenuta dalle guide

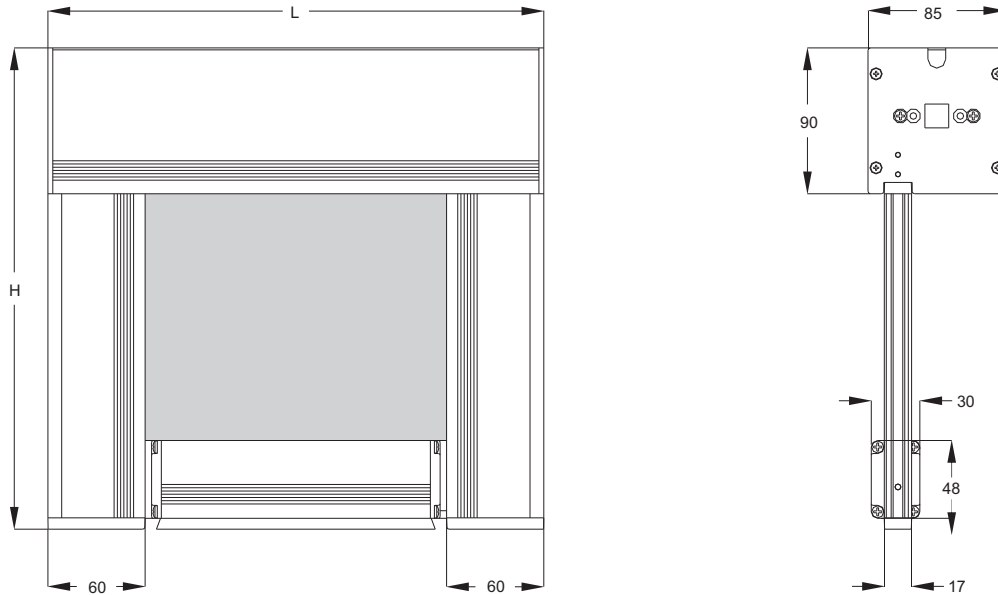

Mod. MBECGF - Fissaggio su flange laterali - dimensioni e ingombri

Tenda sostenuta dalle flange laterali

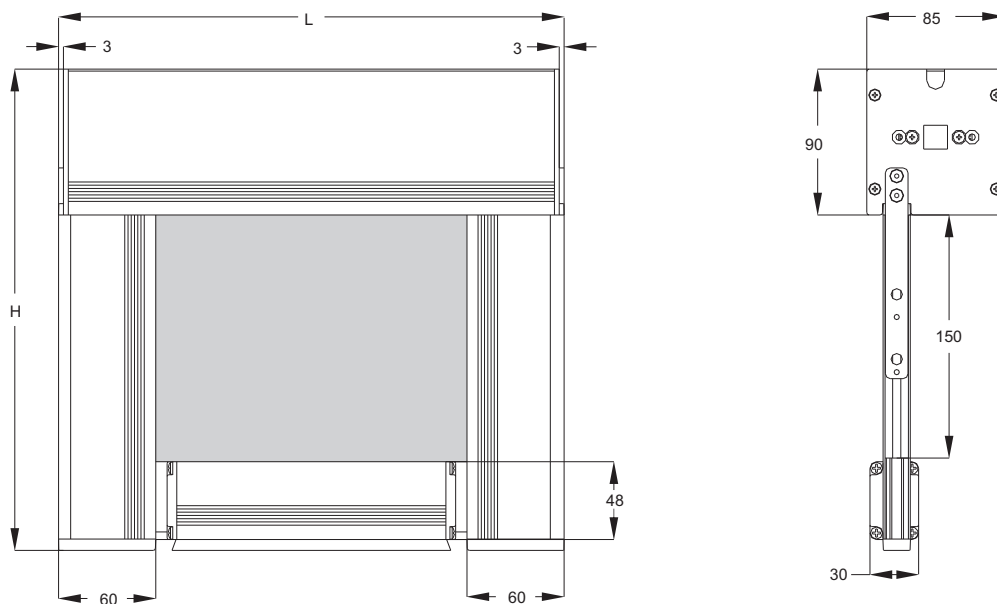



▪Mod. MBECGF - Fissaggio su flange laterali - dimensioni appendice di fissaggio interna (standard)

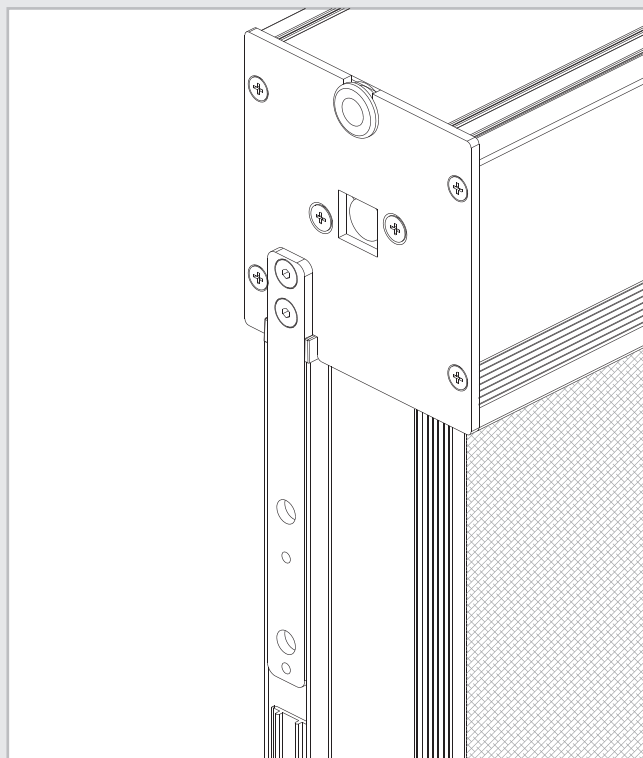
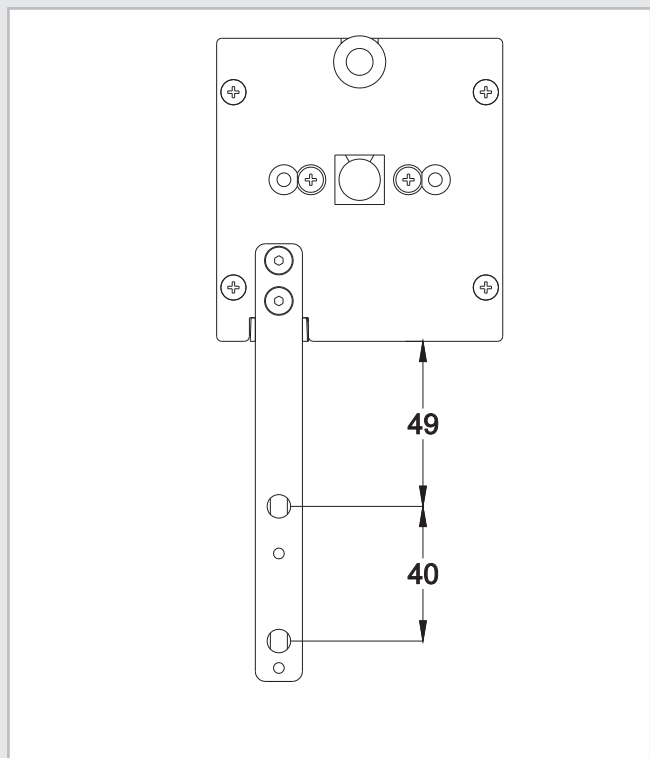

▪Mod. MBECGF - Fissaggio su flange laterali - dimensioni appendice di fissaggio esterna (optional)

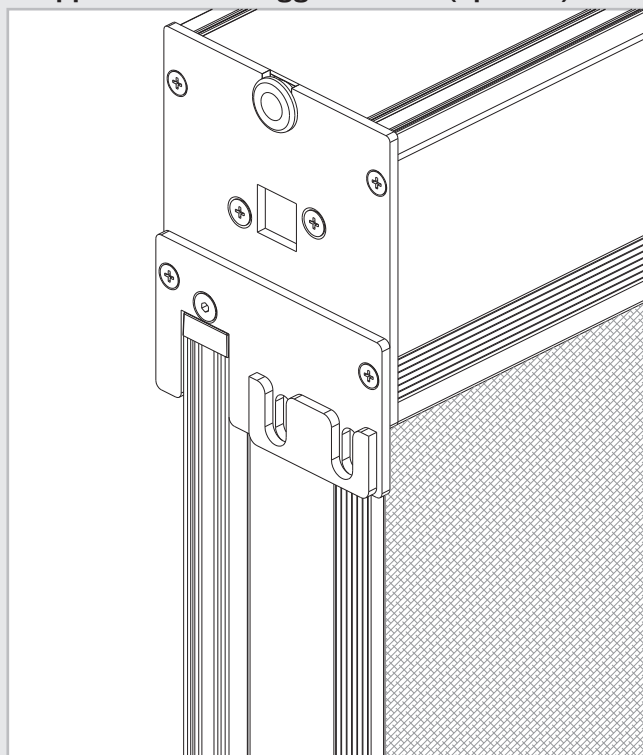
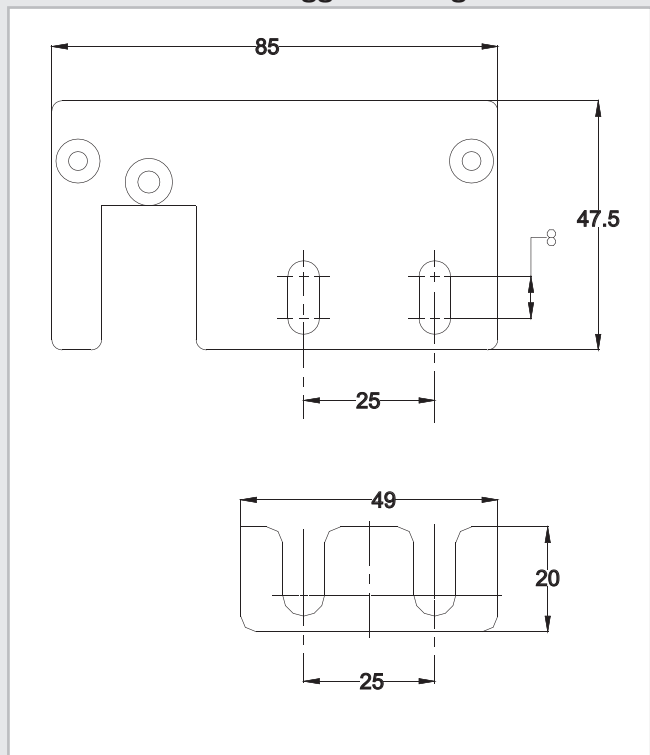



Mod. MBECGA - Fissaggio autoportante

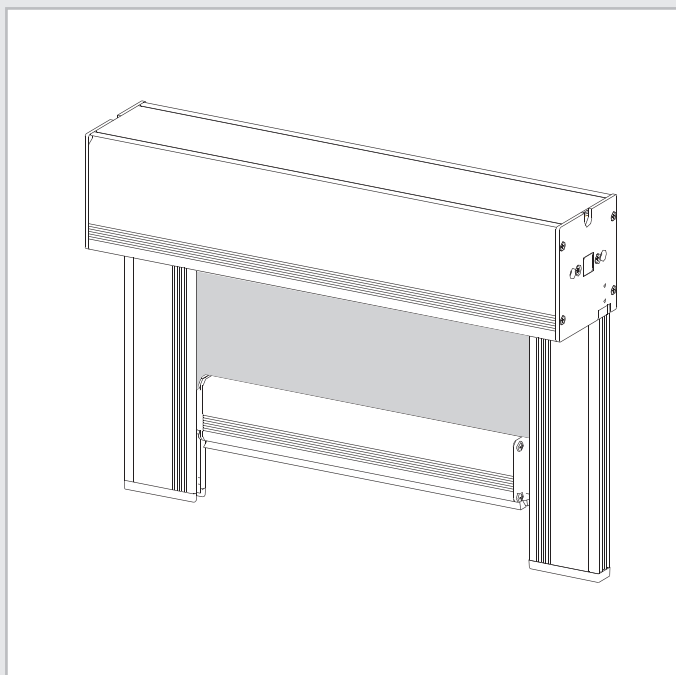

Mod. MBECGF - fissaggio su flange laterali

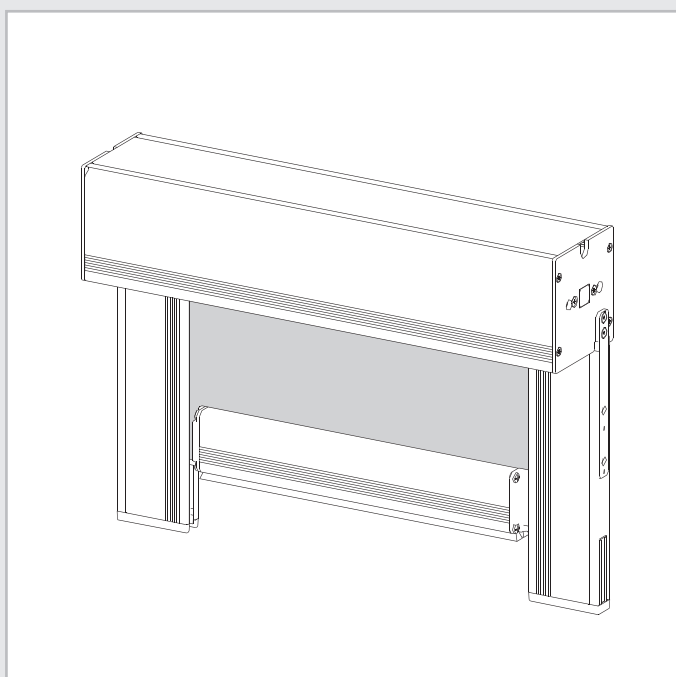

Descrizione di capitolato

- Sistema per tende avvolgibili a rullo da interno con comando di manovra a motore e finecorsa elettronico radio.

Motori Tubolari		
Caratteristiche	um	Ø 40mm
Alimentazione	V/Hz	230Vac 50Hz
Coppia nominale	Nm	6÷13
Velocità nominale	rpm	8÷28
Potenza nominale	W	95÷125
Corrente nominale	A	0,50÷0,55
Tempo di funzion.	min	4
Grado di protezione	IP	44
Frequenza	Mhz	433,42
Canali memorizzabili	n	15

Funzioni	
Funzione MPP	Posizione preferita dei finecorsa
Trasmettitori radio	1 ÷ 24 canali
Altre interfacce	Domotica

- Rulli avvolgitori di Ø 43 e 53mm in alluminio estruso (lega 6060) con nervature antiflessione. Predisposizione del rullo per profilo porta tessuto in PVC (TM)
- Cassonetto di contenimento tenda in alluminio estruso sez. 85x90mm spessore 1,2mm completo di flange laterali in acciaio
- Fissaggio con guide vincolate alle flange laterali o struttura autoportante
- Barra terminale telo in alluminio estruso a vista (lega 6060)
- Guide laterali oscuranti mod. G10 sezione in alluminio estruso a fissaggio laterale con canali di centraggio fori e doppie guarnizioni a spazzola
- Tessuti tagliati ai lati con tecnologia "synkro". Profilo porta tessuto in PVC (TM) disponibile come opzione per rullo Ø 43mm, di serie per rulli Ø 54 (non utilizzabile con tessuti non saldabili)
- Tessuto vincolato ai tappi laterali del fondale

Finiture previste

- Trattamento delle parti in alluminio tramite ossidazione anodica (marchio Qualanod), oppure tramite verniciatura (marchio Qualicoat)
- Tessuti filtranti ignifughi, imputrescibili, lavabili, di composizioni PVC/PES o PVC/FV con diversi gradi di apertura.